

XF™ Series Dripline

The most flexible, kink resistant tubing

Applications

Rain Bird XF™ Series Dripline is the latest innovation in the Rain Bird Xerigation® family. Because it is the most flexible, kink-resistant tubing available, it's ideal for irrigating areas where traditional drip tubing is difficult to install.

XF™ dripline is perfect for small, narrow and tight planting areas, as well as areas with tight curves or many switchbacks.

Because it accepts 17mm insert fittings, and Lock type fittings makes it easier than ever to design with, and install Rain Bird dripline.

XF™ Series Dripline is **simple, reliable** and **durable**.

Features

Simple

- Unique material offers significantly greater flexibility and kink-resistance for fast, easy installation.
- The bend radius for XF™ dripline is 7,6 cm no matter which way you bend the tube. Other driplines will bend 10,2 cm if bending with the natural curve of the coil and only 17,8 cm if bending against the natural curve of the coil.
- Greater flexibility assures design capability of tight curves and spaces.
- Accepts Rain Bird 17mm insert fittings and Lock type fittings.
- Variety of spacing and coil lengths provides design flexibility for a number of nonturfgrass applications.

Reliable

- The pressure-compensating emitter design provides a consistent flow over the entire lateral length ensuring higher uniformity for increased reliability in the pressure range of 0,59 to 4,14 bar.

Durable

- Dual-layered tubing (brown over black) provides unmatched resistance to chemicals, algae growth and UV damage.

Operating Range

- Pressure: 0,59 to 4,14 bar
- Flow rates: 2,3 l/hr
- Temperature:
 - Water: Up to 38° C
 - Ambient: Up to 52° C
- Required Filtration: 120 mesh

Specifications

- OD: 16,10 mm
- ID: 13,61 mm
- Thickness: 1,24 mm
- 33 cm, 40 cm and 50 cm spacing
- Available in 25 m, 50 m, 100 m and 200 m coil

Models

- XFD-23-33-25
- XFD-23-33-50
- XFD-23-33-100
- XFD-23-33-200
- XFD-23-40-50
- XFD-23-40-100
- XFD-23-50-100
- XFD-23-50-200



XF™ Dripline Coil



XF™ Dripline offers increased flexibility for easy installation.

How to Specify/Order:

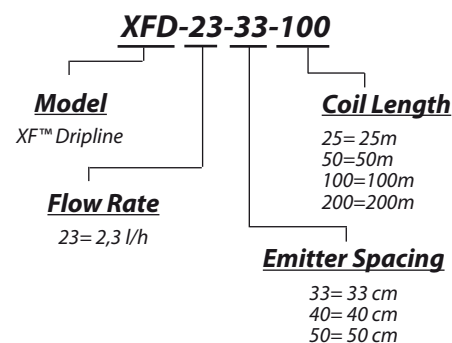

Specifications

The flexible polyethylene tubing shall have factory installed pressure-compensating, inline emitters installed every 33-40-50 cm. The flow rate from each installed inline emitter shall be 2,3 liters per hour when inlet pressure is between 0,59 and 4,14 bar.

The inline emitter diaphragm shall have a pressure-regulating diaphragm with a spring action allowing it to self-rinse if there is a plug at the outlet hole. The bend radius shall be 7,6 centimeters whether bending the tubing with the natural bend of the coil or against it.

The inline emitter inlet shall be raised off the inside tube wall to minimize dirt intrusion.

The XF™ Series Dripline inline tubing shall be manufactured by Rain Bird Corporation.

XF™ Series Dripline Maximum Lateral Length (Feet)

Inlet Pressure psi	Maximum Lateral Length (feet) 12" Spacing Nominal Flow (GPH): 0.6
15	225
25	325
35	371
45	415
55	451

18" Spacing Nominal Flow (GPH): 0.6

15	357
25	458
35	525
45	587
55	639

24" Spacing Nominal Flow (GPH): 0.6

15	448
25	577
35	661
45	739
55	807

XF™ Series Dripline Maximum Lateral Length (Meters)

Inlet Pressure bars	Maximum Lateral Length (meters) 33 cm Spacing Nominal Flow (l/h): 2,3
1,0	49
1,7	73
2,4	94
3,1	109
3,8	121

40 cm Spacing Nominal Flow (l/h): 2,3

1,0	66
1,7	90
2,4	111
3,1	126
3,8	138

50 cm Spacing Nominal Flow (l/h): 2,3

1,0	90
1,7	114
2,4	135
3,1	150
3,8	162

Rain Bird Europe SNC

900, rue Ampère, B.P. 72000
13792 Aix en Provence Cedex 3
FRANCE
Fax: (33) 4 42 24 24 72
rbe@rainbird.eu - www.rainbird.eu

Rain Bird France SNC

900, rue Ampère, B.P. 72000
13792 Aix en Provence Cedex 3
FRANCE
Fax: (33) 4 42 24 24 72
rbf@rainbird.eu - www.rainbird.fr

Rain Bird Sverige AB

Fleningevägen 315
260 35 Ödåkra
SWEDEN
Fax: (46) 42 20 40 65
rbs@rainbird.eu - www.rainbird.se

Rain Bird Ibérica. S.A.

Polígono Ind. Pinares Llanos
c/ Carpinteros, 12, 2ºC
28670 Villaviciosa de Odón, Madrid
ESPAÑA
Fax: (34) 91 632 46 45
rbib@rainbird.eu - www.rainbird.es

Rain Bird Deutschland GmbH

Oberjesinger Str. 53
71083 Herrenberg-Kuppigen
DEUTSCHLAND
Fax: (49) 07032 9901 11
rbd@rainbird.eu - www.rainbird.de

Rain Bird Turkey

İstiklal Mahallesi,
Alemdağ Caddesi, N° 262
81240 Ümraniye İstanbul
TURKEY
Fax: (90) 216 461 74 52
rbt@rainbird.eu - www.rainbird.com.tr