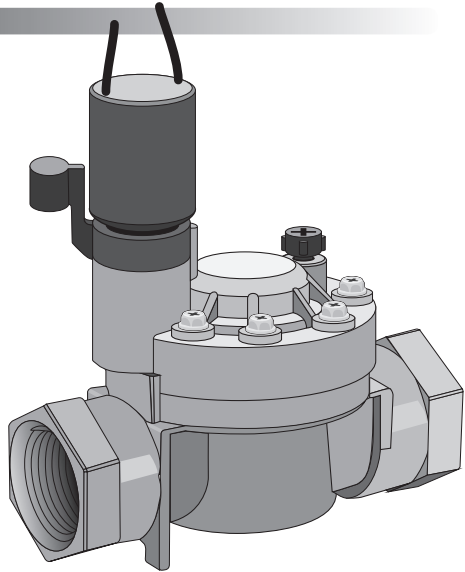

**Introduction**

The Irritrol® 2500 Series is a classic example of value in design. Borrowing heavily from the proven 205 Series valves, the 2500 host a full menu of enhancements including a patented "floating metering system" for consistent performance in dirty water applications and a rugged, double-beaded diaphragm for long-term performance with no leakage. The 2500's manual internal bleed enables the valve to be opened without filling the valve box with water. And servicing is made easy and efficient with captured screws. These are just some of the features that make the 2500 Series valve rugged for a reason.

**Features**

- Patented "floating metering system"
- High-flow, low friction loss design combined with low-flow capability
- Rugged, double-beaded EPDM diaphragm
- Internal and external bleed (flush mode)
- Full stainless steel metering system
- Heavy-duty, corrosion and UV-resistant PVC and stainless steel construction
- Available in female BSP or slip configurations (no male pipe adapter required)
- Floating bleed tube allows thermal expansion without affecting performance.

**Specifications****Models:**

2500MTF Series electric - 1"

**Body Style:**

Globe BSP Female threaded connection

**Dimensions:**

2500: 5 1/8" H x 2 3/4" W x 5" L

**Flow range:** .25 - 30 GPM

**Operating Pressure:** 10-150 PSI

**Electrical**

Solenoid (standard): 24 VAC

Inrush volt-amp: 24 VAC - 9.6 VA

Inrush: 0.4 amps

Holding volt-amp: 24 VAC - 4.8 VA

Holding: 0.2 amps

**Friction Loss Chart (US PSI)****GPM Flow by Size**

Model	Size	.25	2	5	10	15	20	30
2500	1"	5.40	3.82	3.00	2.20	1.90	3.10	5.10

## Recommendations

- In commercial installations, it is advantageous to install the valves in a valve box. This enables the valve to be easily located, accessed, and maintained.
- Partially fill the bottom of the valve box with clean aggregate to facilitate drainage.
- Locate the valve box away from structures, hardscape features (such as sidewalks), and large planting locations.
- Locate the valve box in shrub beds and at right angles to structure locations.
- If valves are installed below grade *without* a valve box, access to the top of the valve should be provided by using a section of 4" PVC pipe and a valve cover installed directly over each valve.

## Installation and Operating Instructions

Automatic in-line valve can be operated either manually or electrically.

In areas where freezing conditions occur, be sure to install a way to drain the system before freezing weather arrives. To do that, use a shut-off valve on the main line feeding the sprinkler system. Shut off the water supply then electrically operate each valve for at least a few minutes (dry run). This vents the upper cavity of the valve and makes sure the valve is completely drained.

Although the valve is rated to 150 psi, a pressure regulator should be used where local water pressure exceeds 80 psi. (See Uniform Plumbing Code, Sec. 1007(b).) We suggest using a pressure regulator with any automatic valve to ensure long life, uniform performance, and controlled operation.

**Step 1** - Flush line thoroughly before installing valve. This valve is designed with slip x slip inlet connections and glues directly to 1" PVC pipe.

**Step 2** - Use PVC pipe cement only. Glue valve directly to 1" PVC pipe. No threading is necessary.

**Caution: Do not plug in the transformer until all valves has been connected.**

**Step 3** - For each location, run one common wire that will serve all the valves at that location. Wiring can be buried

## Guidelines



Using pipe dope on valve connections can cause thread damage and failure of the valve body.  
Use only PTFE tape or pipe thread sealant.

- The valve can be installed at any angle without affecting operation.
- Use direct-burial wire, utilizing different color codes for each station control wire and one color for the common wire to all valves.
- Waterproof wire splice connectors are absolutely essential for proper electric control system operation. Follow the installation instructions provided with the connectors for optimum waterproof splice protection.
- Leaving a wire expansion loop at each valve location on long-run wire lengths is recommended.

underground under the pipes. For runs under 800 feet, use 18 gauge direct burial irrigation wire. For runs over 800 feet, use 14 gauge direct burial irrigation wire.

Each valve has two wires. One will be connected as the "common" wire. Splice the common wire from each valve together to make a single wire. Connect it to the timer. Be sure all splices are joined with wire nuts. Again, make sure all wire splices are waterproof.

The remaining wire on each valve is the "lead" wire. Connect each lead wire to the timer at the numbered terminals, one lead wire per terminal.

**Step 4** - Plug in your timer. Be sure you use only a timer with a Class 2, 24V transformer.

**Step 5** - Turn water supply on.

Note: The valve will remain on until the air in the upper cavity is bled off. To do that, turn the manual bleed screw counterclockwise until water squirts out. Then either tighten the bleed screw or electrically run the valve for about thirty seconds. The valve will shut off within a minute.

**Notice:** This is not a backflow prevention valve. In needs to be installed in conjunction with an approved backflow prevention device. Check state and local plumbing codes prior to installation.