

Introduction

The FLX35 and FLX55 series full and part circle rotary sprinklers are designed specifically for golf course applications.

Manufactured from durable, high-strength engineering plastic and stainless-steel components, these sprinklers incorporate many innovative and time-proven features for lasting, maintenance-free operation.

Prior to installing the sprinkler, read through the recommended installation and start-up procedures. Please observe all **Warnings** and **Cautions** when installing and operating this equipment.



Features

- Adjustable Part circle (40°-330°) and true uni-directional full circle (360°) arc coverage
- Arc adjustment in 5° increments
- Dual trajectory main nozzle adjustment – 25° standard or 15° low angle
- Ratcheting riser in 2° increments
- Nozzle base clutching
- Two back nozzle positions
- Industry's largest precision nozzle selection
- All nozzles are color coded, debris tolerant and threaded in from the front
- Five electric and two hydraulic activation types
 - Electric – Satellite systems – Standard 24 VAC solenoid; SPIKEGUARD 24VAC solenoid; Nickel plated SPIKEGUARD 24VAC solenoid
 - Electric – 2-wire systems – DC Latching solenoid; Integrated GDC module w/DC latching solenoid
 - Hydraulic – Normally Open valve in head; Check-O-Matic (requires remote valve)
- Constant velocity drive and variable stator provide consistent rotation speeds
- Manual control at the sprinkler ON-OFF-AUTO (electric models only)
- Selectable/lockable pressure regulation settings; 50 psi (3,4 bar), 65 psi (4,5 bar), 80 psi (5,5 bar) or 100 psi (6,9 bar)
- Indestructible stainless steel valve seat and valve communication tube
- Body inlet rock screen serviceable from the top
- All internal components are serviceable from the top of the sprinkler

Specifications and Performance/Application Data

FLX35 Series

















- **Radius:** 43'-83' (13,1-25,3 m)
- **Flow Rate:** 8.2-47.3 GPM (31-179 LPM)
- **Trajectory:** Selectable 15° or 25°
- **Arc:** Full Circle (360°) or adjustable part circle (40°-330°)
- **Recommended Operating Pressure:** 65-100 PSI (4,5-6,9 Bar)
- **Minimum Pressure:** 40 PSI (2,8 Bar)
- **Maximum Pressure:** 150 PSI (10,3 Bar)
- **Precipitation Rate:**
 - Minimum: 0.43"/hr (10,9 mm/hr)
 - Maximum: 0.76"/hr (19,3 mm/hr)
- **Body Height:** 10" (254 mm)
- **Pop-Up Height to Nozzle:** 4 3/16" (106 mm)
- **Inlet Size:** 1" (25 mm) NPT, BSP or ACME
- **Five electric activation types:**
 - Standard Solenoid** - 24 VAC, 50/60 Hz, 0.30 Amps Inrush, 0.20 Amps Holding
 - SPIKEGUARD Solenoid** - 24 VAC, 50/60 Hz, 0.12 Amp Inrush, 0.10 Amp Holding
 - Nickel Plated SPIKEGUARD Solenoid** - 24 VAC, 50/60 Hz, 0.12 Amp Inrush, 0.10 Amp Holding
 - DC Latching Solenoid** - Momentary Low Voltage Pulse
 - Integrated GDC Module w/ DC Latching Solenoid** - Momentary Low Voltage Pulse
- **Manual Control (Electric only):** On-Off-Auto
- **Check-O-Matic Model** checks up to 37' (11,2 m) of elevation
- **Eight Nozzle Variations**

FLX55 Series

- **Radius:** 55'-92' (16,8-28 m)
- **Flow Rate:** 14.1-61.3 GPM (53,4-232 LPM)
- **Trajectory:** Selectable 15° or 25°
- **Arc:** Full Circle (360°) or adjustable part circle (40°-330°)
- **Recommended Operating Pressure:** 65-100 PSI (4,5-6,9 Bar)
- **Minimum Pressure:** 40 PSI (2,8 Bar)
- **Maximum Pressure:** 150 PSI (10,3 Bar)
- **Precipitation Rate:**
 - Minimum: 0.45"/hr (11,4 mm/hr)
 - Maximum: 0.94"/hr (23,9 mm/hr)
- **Body Height:** 11" (289 mm)
- **Pop-Up Height to Nozzle:** 4 3/16" (106 mm)
- **Inlet Size:** 1.5" (40 mm) NPT, BSP or ACME
- **Five electric activation types:**
 - Standard Solenoid** - 24 VAC, 50/60 Hz, 0.30 Amps Inrush, 0.20 Amps Holding
 - SPIKEGUARD Solenoid** - 24 VAC, 50/60 Hz, 0.12 Amp Inrush, 0.10 Amp Holding
 - Nickel Plated SPIKEGUARD Solenoid** - 24 VAC, 50/60 Hz, 0.12 Amp Inrush, 0.10 Amp Holding
 - DC Latching Solenoid** - Momentary Low Voltage Pulse
 - Integrated GDC Module w/ DC Latching Solenoid** - Momentary Low Voltage Pulse
- **Manual Control (Electric only):** On-Off-Auto
- **Check-O-Matic Model** checks up to 37' (11,2 m) of elevation
- **Nine Nozzle Variations**

Nozzle Performance Chart

FLX35 Series Performance Chart—25°



















Front Nozzle Positions	Nozzle Set 30		Nozzle Set 31		Nozzle Set 32		Nozzle Set 33		Nozzle Set 34		Nozzle Set 35		Nozzle Set 36		Nozzle Set 37		
																	
	102-2208		102-6906		102-0726		102-6907		102-0728		102-6955		102-6935		102-6936		
	Yellow	Beige	Yellow	Brown	Yellow	Yellow	Yellow	Yellow	Yellow	Yellow	Yellow	Green	Green	Green	Green	Green	
	102-5670	102-6942	102-5670	102-5671	102-5670	102-6884	102-5670	102-6884	102-5670	102-6884	102-5670	102-6885	102-6531	102-6885	102-6531	102-6885	
Back Nozzle Positions																	
	102-4335		102-4335		102-4335		102-4335		102-4335		102-4335		102-4335		102-4335		
	PSI	Radius	GPM	Radius	GPM	Radius	GPM	Radius	GPM	Radius	GPM	Radius	GPM	Radius	GPM	Radius	GPM
	50	43	8.2	53	13.8	56	18.3	61	21.7	65	25.3	—	—	—	—	—	—
65	45	10.0	53	15.5	59	20.5	64	24.4	68	28.2	72	34.1	—	—	—	—	
80	46	11.5	57	17.3	62	22.7	67	27.1	71	31.1	75	37.8	78	40.3	80	44.0	
100	47	13.4	59	19.1	65	24.9	70	29.8	74	34.1	79	40.9	81	43.8	83	47.3	

FLX35 Series Performance Chart—15°

PSI	Radius	GPM	Radius	GPM	Radius	GPM	Radius	GPM	Radius	GPM	Radius	GPM	Radius	GPM	Radius	GPM
50	43	8.2	52	13.6	58	18.1	61	21.5	62	25.6	—	—	—	—	—	—
65	45	10.0	54	15.3	60	20.3	64	24.2	65	27.3	69	33.1	—	—	—	—
80	46	11.5	58	17.2	64	22.6	69	26.8	69	30.2	75	36.8	76	39.7	76	42.9
100	47	13.4	60	19.0	66	24.7	71	29.5	72	32.9	78	39.5	82	42.6	82	46.1
Stator	102-6929 Blue		102-1939 Yellow						102-1940 White							
Conversions	FLX35-3134						FLX35-3537									

■ Not recommended at these pressures. Radius shown in feet.
 Toro recommends the use of a 1/4" swing joint at flows over 25-GPM (95-LPM). Sprinkler radius data collected in Toro's zero wind test facility per ASAE standard S398.1.
 Actual site conditions must be considered when selecting the appropriate nozzle.
 All sprinklers are equipped with the selectable pilot valve that allows settings at 50, 65, 80 and 100 PSI.

FLX55 Series Performance Chart—25°

Front Nozzle Positions	Nozzle Set 51		Nozzle Set 52		Nozzle Set 53		Nozzle Set 54		Nozzle Set 55		Nozzle Set 56		Nozzle Set 57		Nozzle Set 58		Nozzle Set 59		
																			
	102-6906		102-0726		102-6907		102-0728		102-6955		102-6935		102-6936		102-6909		102-4259		
	Yellow	Brown	Yellow	Yellow	Yellow	Yellow	Yellow	Yellow	Yellow	Green	Green	Green	Green	Green	Green	Green	Green	Green	
	102-5670	102-5671	102-5670	102-6884	102-5670	102-6884	102-5670	102-6884	102-5670	102-6885	102-6531	102-6885	102-6531	102-6885	102-6531	102-6885	102-6531	102-6885	
Back Nozzle Positions																			
	102-4335		102-4335		102-4335		102-4335		102-4335		102-4335		102-4335		102-4335		102-4335		
	PSI	Radius	GPM	Radius	GPM	Radius	GPM	Radius	GPM	Radius	GPM	Radius	GPM	Radius	GPM	Radius	GPM	Radius	GPM
	50	55	14.1	57	18.5	62	22.3	66	25.8	—	—	—	—	—	—	—	—	—	—
65	57	15.8	60	20.9	65	25.1	69	28.7	73	35.9	—	—	—	—	—	—	—	—	
80	59	17.5	61	23.1	68	27.8	72	31.7	76	39.7	80	43.1	83	48.2	85	50.0	89	57.5	
100	61	19.3	63	25.3	71	30.3	75	34.5	80	43.5	83	49.0	88	51.5	90	53.9	92	61.3	

FLX55 Series Performance Chart—15°

PSI	Radius	GPM	Radius	GPM	Radius	GPM	Radius	GPM	Radius	GPM	Radius	GPM	Radius	GPM	Radius	GPM	Radius	GPM
50	55	14.0	59	16.5	62	22.2	63	25.6	—	—	—	—	—	—	—	—	—	—
65	56	15.6	62	20.7	65	25.0	66	28.5	75	35.3	—	—	—	—	—	—	—	—
80	59	17.4	66	23.0	69	27.7	70	31.5	78	39.0	78	42.4	79	46.9	79	49.5	82	57.2
100	60	19.2	68	25.1	71	30.2	72	34.3	80	41.9	81	47.2	83	52.1	83	53.4	85	60.8
Stator	102-1939 Yellow						102-1940 White						102-1941 White					
Conversions	FLX55-5154						FLX55-5558						FLX55-59					

■ Not recommended at these pressures. Radius shown in feet.
 Toro recommends the use of a 1/4" swing joint at flows over 25-GPM (95-LPM). Sprinkler radius data collected in Toro's zero wind test facility per ASAE standard S398.1.
 Actual site conditions must be considered when selecting the appropriate nozzle.
 All sprinklers are equipped with the selectable pilot valve that allows settings at 50, 65, 80 and 100 PSI.

Sprinkler Spacing Guidelines

• Square Spacing

- No wind - 55% of diameter
- 4 mph wind - 50% of diameter
- 8 mph wind - 45% of diameter

• Triangular Spacing

- No wind - 60% of diameter
- 4 mph wind - 55% of diameter
- 8 mph wind - 50% of diameter

• Single-Row Spacing

- No wind - 50% of diameter
- 4 mph wind - 50% of diameter
- 8 mph wind - 45% of diameter

Note: Designing for zero (0) mph wind conditions is not recommended. Design for worst wind conditions.

For additional information, refer to Toro Technical Data Manual, form number 490-1737.

Precipitation Rate Formulas

- Square-spaced sprinklers in pattern:

$$\frac{\text{GPM of full circle} \times 96.3}{(\text{Spacing})^2}$$

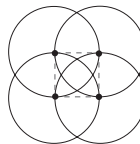

- Triangular-spaced sprinklers in pattern:

$$\frac{\text{GPM of full circle} \times 96.3}{(\text{Spacing})^2 (0.866)}$$

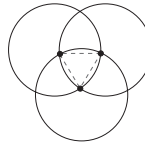

- Area and flow:

$$\frac{\text{Total GPM of zone} \times 96.3}{\text{Total irrigated Square feet of zone}}$$

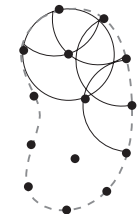

- Single row:

$$\frac{\text{GPM of full circle} \times 96.3}{(\text{Spacing}) (\text{Scallop})}$$

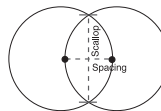

Toro Swing Joints

Use Toro swing joints to connect the sprinklers to the lateral/main line pipe.

Toro swing joints provide swivel joints that allow the sprinkler body to be easily positioned to finished grade and prevents pipe breakage by providing the flexibility to allow downward movement if the sprinkler is run over by heavy equipment.

For installation using pipe thread connections (NPT or BSP), use PTFE tape only to seal all threaded connections.

CAUTION: Use PTFE tape only for sealing pipe thread connections. Use of pipe dope or other paste sealants can cause deterioration of the sprinkler body threads.

Tape should be applied to the male threaded fitting in compliance with the tape manufacturer recommendations. Thread the fitting into the mating female threaded fitting in the sprinkler body and service tee and tighten securely.

For installation using ACME thread connections, do not apply additional sealant.

CAUTION: ACME fittings incorporate an o-ring seal that requires no additional sealant.

Sprinkler fitting installation - Thread the ACME fitting into the sprinkler body and hand tighten until it stops. No additional tightening or loosening is required.

CAUTION: Loosening beyond 270° will result in a thread leak.

Lateral/Mainline pipe installation - Thread the ACME fitting into the lateral/main line service tee and hand tighten until it stops, then loosen up to one full turn to ensure flexible movement of the swing joint.

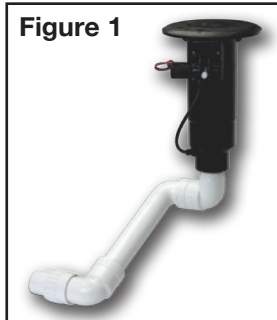

Wire Splices

CAUTION: Communication cable or station wire connections will deteriorate when exposed to moisture and earth ground causing shorts or open circuits resulting in improper system operation.

All direct burial wire connections must be done with approved waterproof connections installed in compliance with the manufacturer specifications. Contact your Toro Golf Distributor for approved waterproof connectors.

Always provide a wire service loop for each splice to ensure sufficient wire is available should future servicing be required.

Connecting Hydraulic Control Tubing

Step 1 – Route control tubing from the controller to the sprinkler location(s).

Note: Leave an 18" (45.7 cm) service loop of tubing at each sprinkler to facilitate movement of sprinkler and service operations. Refer to **Hydraulic Control Systems Table** for tubing run length and sprinkler elevation information.

Step 2 – Flush tubing thoroughly to remove all air and debris.

Step 3 – Remove the tube retainer and poly cap from the tubing adapter at the base of the sprinkler.

Step 4 – Slide the tube retainer over the end of the control tubing and attach tubing to adapter.

Step 5 – Slide tube retainer over the adapter area to secure tubing.

Hydraulic Control Systems Table		
Type of System*	Maximum Distance From Controller	Elevation Restrictions
Normally Open (01) with 3/16" Control Tubing	500'	Valve elevation should not exceed 25' above controller elevation or 70' below controller elevation.
Normally Open (01) with 1/4" Control Tubing	1000'	Valve elevation should not exceed 25' above controller elevation or 70' below controller elevation

- * - All hydraulic connections on Toro valves are 1/4" insert type.
- Control line pressure must be equal to or greater than mainline pressure.
- Control line pressure range is 40 to 150 PSI.

System Start Up

⚠ WARNING! Never stand or lean over the sprinkler while the irrigation system is being filled, during manual or automatic operation or when performing sprinkler service procedures. Direct contact with irrigation spray, a failed or improperly installed sprinkler connection or sprinkler components forcibly ejected upward under pressure can cause serious injury.

The following is a recommended procedure that will protect system components during system start-up. The procedure is based on a velocity fill rate of less than 2' (.61 m) per second. See Table 3 below.

Step 1 – Use a jockey pump only to fill the system at a velocity fill rate of less than 2' (0.61 m) per second.

⚠ CAUTION: Failure to comply with recommended fill rate will increase line pressure resulting in a water hammer effect that could damage sprinklers and piping components. See Warning above.

Step 2 – Use quick coupler keys at all tees and greens with quick coupler valves to bleed air from the system lines during the filling process. For best results, do not compress air and then relieve it – bleed the air continuously while filling the system.

Step 3 – After water has filled all lines and all air is removed, remove the quick coupler keys.

Recommended System Fill Rate

Pipe Size		Flow		Velocity		Pipe Size		Flow		Velocity	
in.	cm	GPM	LPM	ft/sec	m/sec	in.	cm	GPM	LPM	ft/sec	m/sec
1/2	1.3	2	7.6	1.60	0.49	3	7.6	45	170.3	1.86	0.57
3/4	1.9	3	11.4	1.92	0.59	4	10.1	75	283.9	1.87	0.57
1	2.5	5	18.9	1.50	0.46	6	15.2	150	567.8	1.73	0.53
1-1/4	3.1	10	37.9	1.86	0.57	8	20.2	250	946.3	1.70	0.52
1-1/2	3.8	10	37.9	1.41	0.43	10	25.4	450	1703.0	1.97	0.60
2	5.0	20	75.7	1.80	0.55	12	30.5	500	1893.0	1.55	0.47
2-1/2	6.4	30	113.6	1.84	0.56						

Winterization

Winterizing the irrigation system is required in freezing climates to prevent damage from water expansion when it freezes. Following are three key points for successfully winterizing the system, however, Toro provides a complete “Winterization and Pressurization Guide” (P/N 373-0849) that is available from your local Toro Distributor.

- Open low point drains, vent high points and allow the system to drain naturally several days prior to using compressed air.
- Attach compressor to the highest point possible and use the compressed air to force remaining water out of the low points and close vents and drains working from high points to low points when clear air is observed.
- Regulate compressed air to 50 psi and cycle each sprinkler **ONCE** until clear.

Arc Adjustment Procedure

The FLX35 and FLX55 sprinkler models can be operated in full-circle or part circle operation. In part-circle operation, the sprinkler arc can be adjusted from 40°– 330°. When full-circle (360°) operation is selected, the sprinkler will rotate in a clockwise direction only. The arc is factory preset at 180°. The left side of the arc, located at the end of the counterclockwise rotation, is non-adjustable (fixed). Therefore, all arc adjustments, whether increasing or decreasing, will change the right side of the arc, located at the end of the clockwise rotation.

Step 1 – Using the sprinkler tool, pull the sprinkler riser up from the body. See **Figure 2**.

Step 2 – Find the sprinkler left stop by rotating the turret counterclockwise until it stops. The left stop indicates the fixed stop of the arc. See **Figure 3**.

Step 3 – Check the left stop alignment with the left most area being irrigated. Adjust as follows by ratcheting the riser clockwise or counterclockwise until the sprinkler left stop points to the correct area. See **Figure 4**.

1. If the left stop falls short of the desired border, rotate the turret counterclockwise to the stop, then ratchet the riser until it is aligned with the left watering border. See **Figure 4**.
2. If the left stop exceeds the border, rotate the turret clockwise to the right stop. Continue to advance the turret the same distance that the left stop exceeded the border. See **Figure 5**.

Step 4 – Find the sprinkler right stop by rotating the turret clockwise until it stops. See **Figure 5**.

Note: If the sprinkler is set at 360° (full-circle), it will rotate clockwise only.

Step 5 – Adjust the arc while the turret is pointing at the right stop. Hold the sprinkler riser firmly while pressing the release on the adjustment band. Rotate the turret counterclockwise or clockwise to the desired right stop. See **Figure 6**.

Step 6 – Activate the sprinkler to check proper arc setting and adjust as necessary.

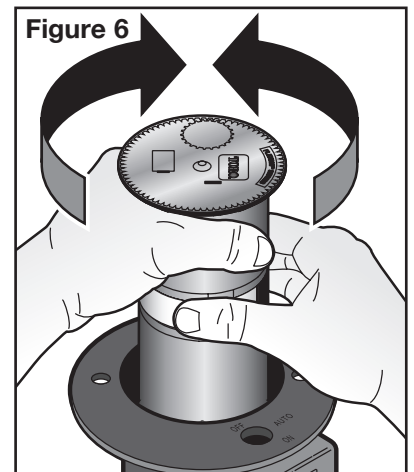
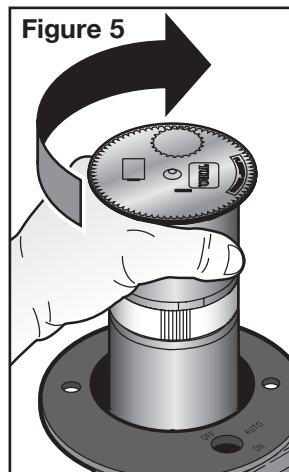
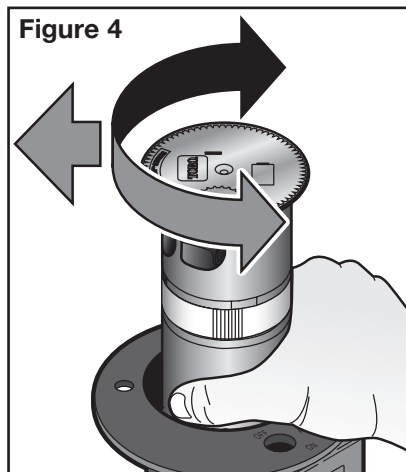
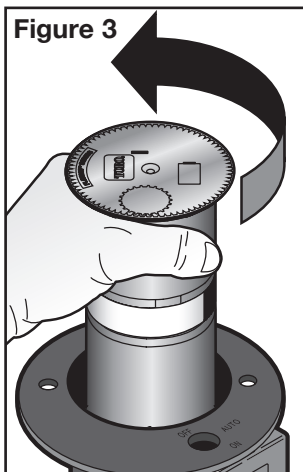
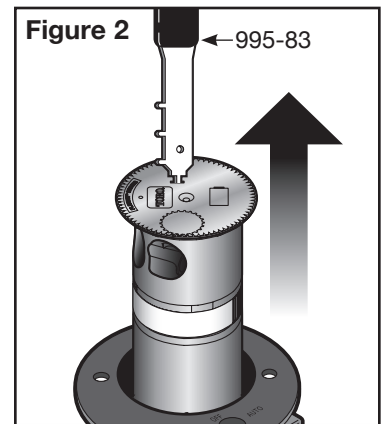

Adjustment Band Indicators

Figure 7

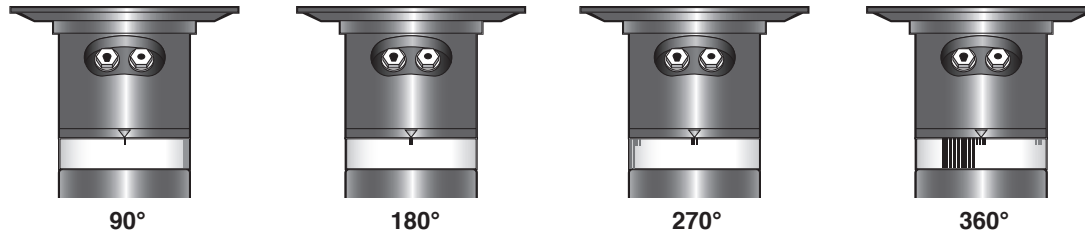

For reference, the adjustment band of the FLX35 and FLX55 has markers at predetermined arcs. By aligning the adjustment band indicators to the turret arrow, you can set the sprinkler arc to 90°, 180°, 270° or 360°. The arc is adjustable from 40°–330° in 5° increments. See **Figure 7**.

Trajectory Adjustment Procedure

The FLX35 and FLX55 sprinkler models are designed with a dual-trajectory main nozzle.

Use the following procedure to select the sprinkler trajectory of 15° or 25°.

- Step 1** – Using the multi-purpose tool (P/N 995-83), pull the riser from the provided slot in the cap. Pull the riser assembly until there is enough clearance for handling and hold onto the riser body.
- Step 2** – Remove cap screw and cap to unlock the main nozzle.
- Step 3** – Use a 5/8" nut driver (P/N 995-99) to turn the main nozzle assembly. Turn the main nozzle assembly clockwise until the angle indicator points towards the right to set 25° trajectory. Continue turning the main nozzle clockwise until the angle indicator points towards the left to set 15° trajectory. See **Figure 8** and **9**.
- Step 4** – Replace the cap. Make sure the main nozzle is secured and retained by the cap.
- Step 5** – Secure the cap with the cap screw.

Figure 8

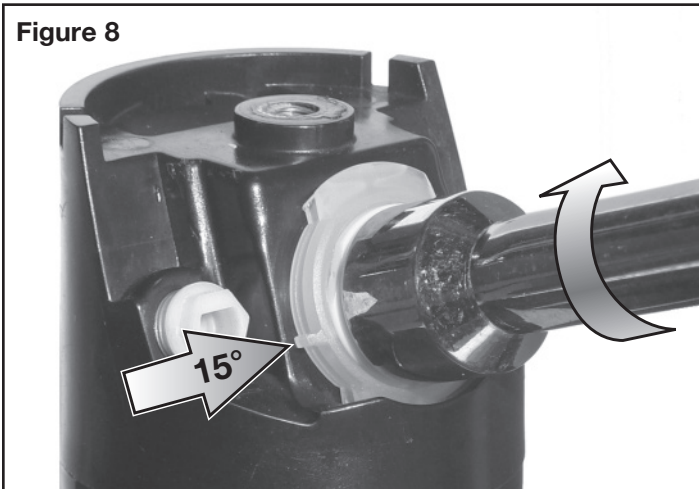
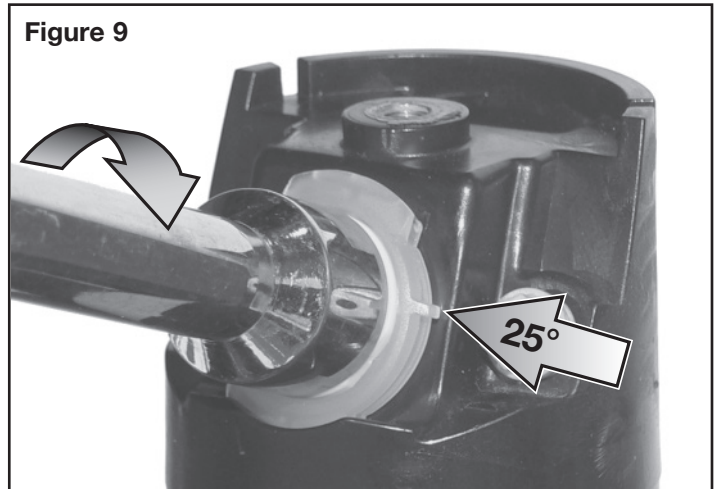

Figure 9



Radius Reduction - FLX34/54 and FLX35/55 Only (Not for FLX35-6/55-6)

For further refinement of the sprinkler's radius, an optional radius reduction screw (363-4839) can be added to break up the main nozzle spray. The sprinkler cap provides an installation hole just above and in front of the main nozzle. Using a 3/32" Allen wrench (P/N 995-82), thread the radius reduction screw clockwise into the installation hole. Turn the sprinkler ON and continue to thread the screw clockwise into the main nozzle stream until the desired result is achieved. See **Figure 10**.

Figure 10

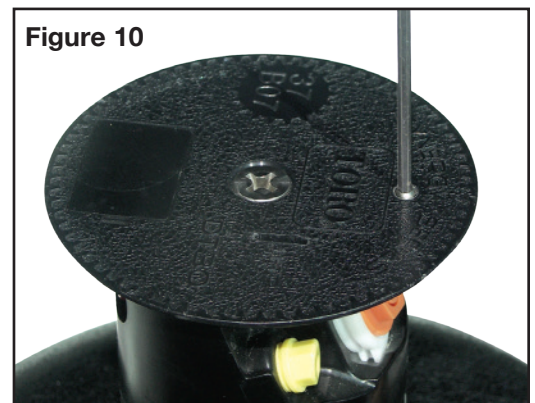

Pilot Valve Operation (Electric Models Only)

The pilot valve controls the operation of the main valve located in the base of the sprinkler body. The main valve is operated by the release of water metered through the pilot valve when it is activated either manually at the sprinkler or by the irrigation system controller. Another important function of the pilot valve is to regulate the water pressure to the sprinkler nozzle. Pressure regulation compensates for large variations within the system and maintains a constant pressure for optimum sprinkler operation. The pilot valve is factory set to regulate to one of four pressure levels: 50 psi (3.5 bar), 65 psi (4.6 bar), 80 psi (5.6 bar) or 100 PSI (7.0 bar).

Change the pilot valve operating pressure by loosening the thumb screw that secures the selector lever. Position the selector lever to the desired operating pressure and hand-tighten the nut. See **Figure 11**.

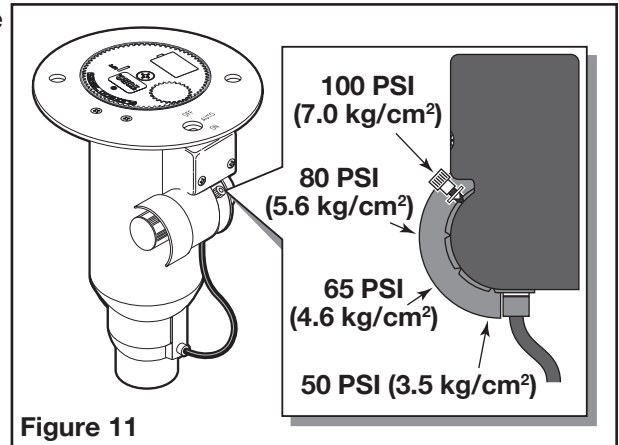

Troubleshooting

Possible equipment failures with causes and corrective action are listed below.

Sprinkler won't rotate

- Debris wedged between stator and turbine
 - Remove obstruction
- Drive assembly defective
 - Replace drive assembly
- Nozzle base assembly defective
 - Replace riser assembly

Head sticks up

- Dirt in riser assembly
 - Flush out. (See **Flushing Sprinklers**)
- Damaged or missing return spring
 - Replace
- Damaged riser
 - Replace

Poor distribution pattern

- Nozzle plugged with debris
 - Clean or replace nozzle
- Nozzle orifice damaged
 - Replace nozzle
- Low operating pressure
 - Determine why system overloaded and correct

Valve won't close (Electric)

- Continuous 24 VAC to sprinkler
 - Check controller for voltage source
- Debris in Pilot Valve
 - Disassemble and remove all debris
- Leak in pilot valve assembly
 - Replace pilot valve assembly
- Plugged supply screen on piston
 - Clean or replace screen
- Manual control selector on pilot valve assembly turned to "ON" position
 - Turn to "AUTO" position
- Plunger movement restricted
 - Inspect and clean or replace
- Valve cylinder misaligned with sprinkler body communication tube
 - Remove valve assembly and install correctly
- Foreign object keeping valve from seating
 - Remove, clean and check valve for damage. Replace if necessary
- Damaged piston seal or piston assembly
 - Replace valve assembly

Valve won't close (Hydraulic)

- Leak in control tubing
 - Isolate and repair
- Pilot valve leak in controller
 - Confirm by observing constant dripping from discharge line of controller. Refer to Controller Service Manual
- Valve cylinder misaligned with sprinkler body communication tube
 - Remove valve assembly and install correctly
- Foreign object keeping valve from seating
 - Remove, clean and check valve for damage. Replace if necessary
- Damaged piston seal or piston assembly
 - Replace valve assembly

Valve won't open (Electric)

- Control (field) wires severed
 - Isolate and repair
- No power to controller
 - Establish controller power
- No power from controller to solenoid
 - Check for blown fuse and replace
- Manual control selector on pilot valve assembly turned to "OFF" position
 - Turn to "AUTO" position
- Pilot valve solenoid inoperative
 - Remove and replace
- Pilot valve plunger movement restricted
 - Inspect, clean and/or replace
- No supply from main valve
 - Debris in control tube, main valve assembly and/or communication passages in body. Flush thoroughly

Valve won't open (Hydraulic)

- Plugged controller discharge line or discharge port in pilot valve
 - Verify by checking for discharge at discharge line when station is activated. If no discharge, refer to Controller Service Manual

Sprinkler Weeping (Slow leak in valve)

- Damaged or blocked valve seat
 - Remove blockage and, if necessary, replace valve assembly
- Damaged piston seal or piston assembly
 - Replace valve assembly
- Damaged pilot valve discharge seat
 - Clean or replace pilot valve
- Damaged pilot valve plunger
 - Clean or replace plunger
- Low pressure on supply line (N.O. Hydraulic Models)
 - Check for low pressure reason and correct
- Elevation of normally closed sprinkler exceeds 75' (22.9 m) differential

Several valves on different stations fail to close (Hydraulic)

- Control tubing leak which lowers supply pressure to other stations
 - Turn controller from station to station until a station is reached where only valves on that station stay open
The leak would be in the tubing on that station. Isolate and repair
- Leak in supply line to controller
 - Verify by checking pressure in all control lines
- Leak in controller pilot valve
 - Verify by constant discharge from controller
- Plugged supply line filter
 - Replace filter if more than 3 psi (0.21 bar) differential exists

Servicing Procedures

The FLX35 and FLX55 series sprinklers are designed to provide the user trouble-free operation for many years without scheduled maintenance. If it becomes necessary to disassemble the sprinkler to correct a malfunction or replace a component, all internal parts of the sprinkler can be accessed from the top. Refer to the Troubleshooting Procedure in this manual in the event of a malfunction. Some special tools are required for disassembly and/or maintenance of the sprinkler and are available from your Toro dealer.

Servicing Sprinkler Mechanism

WARNING! Never stand or lean over the sprinkler while the irrigation system is being filled, during manual or automatic operation or when performing sprinkler service procedures. Direct contact with irrigation spray, a failed or improperly installed sprinkler connection or sprinkler components forcibly ejected upward under pressure can cause serious injury.

Servicing Sprinkler Mechanism

Note: Refer to **Figure 12** for the following procedure.

Step 1 – Insert the hooked end of the multi-purpose tool (P/N 995-83) into the slot in the cap (2) and pull the riser assembly up until there is enough clearance to handle.

Step 2 – Insert the hooked end of the tool into the snap ring slot (3). Pull the snap ring inward towards the sprinkler assembly, then upward to remove from the groove in body. Hold onto the riser body (13) and carefully extract it from the sprinkler body.

CAUTION: The seal/retainer (4) will rapidly move upward (caused by the decompressing spring [5]) as it clears the sprinkler body.

Step 3 – Three small tabs are provided on the edge of the multi-purpose tool. Insert tabs into the debris filter screen (17). Holding the plastic base of riser assembly, turn the screen counterclockwise to remove.

Step 4 – Remove the variable stator (16) from riser assembly.

Step 5 – Remove the drive assembly retaining screw (14) and pull the drive assembly (15) using a pair of pliers. See **Figure 13**.

CAUTION: When removing or installing the drive assembly, do not use the turbine to pull the drive assembly. Use the drive assembly body to extract it out. Failure to comply may cause separation of the drive assembly components.

Note: During reassembly, ensure drive assembly is properly aligned with the retaining screw.

Step 6 – Using a 5/8" nut driver (P/N 995-99), unscrew main nozzle (12) from nozzle base assembly.

Step 7 – Using a 5/16" nut driver (P/N 995-105), unscrew the inner (7) and intermediate (8) nozzles.

Step 8 – Remove the cap screw (1) and cap (2).

Note: During reassembly, ensure the cap is correctly installed with the Toro Logo positioned over the main nozzle (12) and the snap ring is correctly installed and fully seated in the sprinkler body.

Note: During reassembly, ensure that the inner nozzle orifice is aligned as shown. 

Step 9 – Thoroughly clean and inspect all parts and replace as necessary. Reassemble in reverse order.

Step 10 – When installing the riser assembly to the sprinkler body, align the ratchet ring with the inside body rib. Use the indicator on top of the sprinkler body to center the ratchet ring. See **Figure 14**.

Figure 12

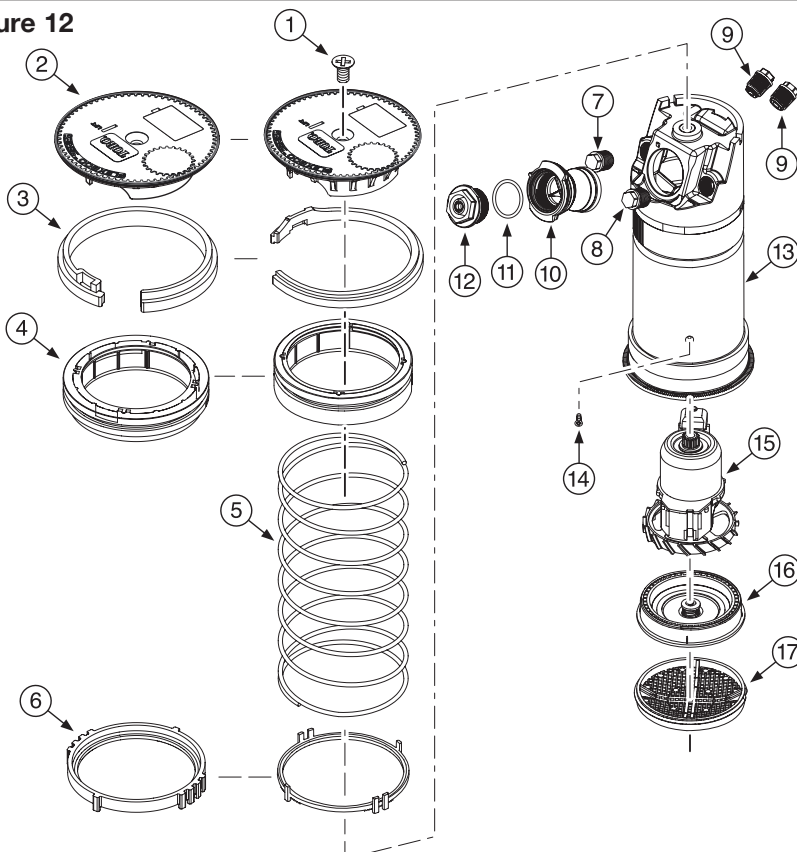

Figure 13

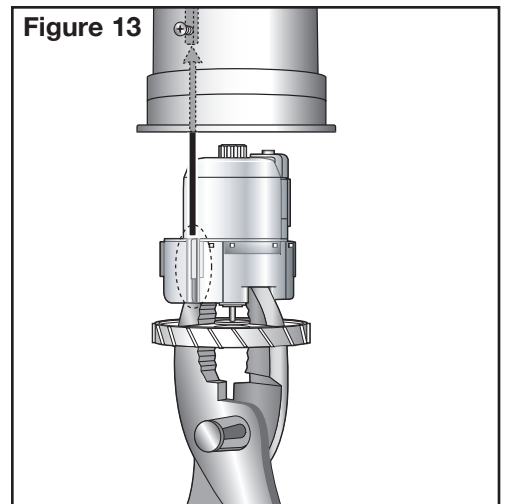
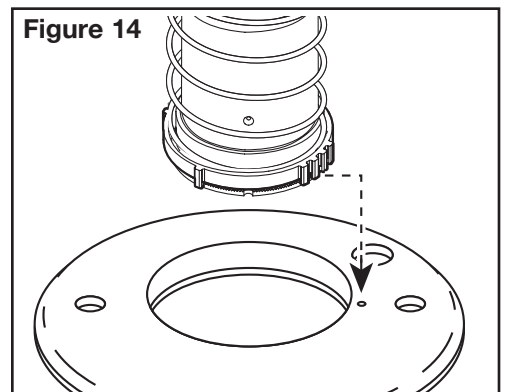

Figure 14



Servicing Main Valve

⚠ WARNING! If the valve snap ring is difficult to remove, residual water pressure may be remaining in the system. To prevent possible serious injury due to valve being ejected upward under pressure, confirm the following conditions exist prior to removing the snap ring and valve.

- A. Water supply to sprinkler is shut off at source.
- B. All pressure is bled from system, including control tubes.
- C. AC power is disconnected at source.

Step 1 – See WARNING above. To remove valve assembly, squeeze snap ring ears together with snap ring pliers (P/N 995-100) and remove snap ring from sprinkler body. See **Figure 15**.

Step 2 – Use valve removal tool P/N 995-08 for FLX35 or 995-09 for FLX55 to remove valve assembly from base of sprinkler body. Valve removal tool is inserted into sprinkler body and pushed through valve ribs. A slight twist will catch tool under ribs enabling valve removal by pulling straight up and out. See **Figure 16**.

Note: If valve removal tool is not available, use snap ring pliers to grasp rib of valve cylinder assembly and pull up and out of sprinkler body.

Step 3 – Reinstall valve assembly using valve insertion tool P/N 995-76 for FLX35 or 995-101 for FLX55 as follows:

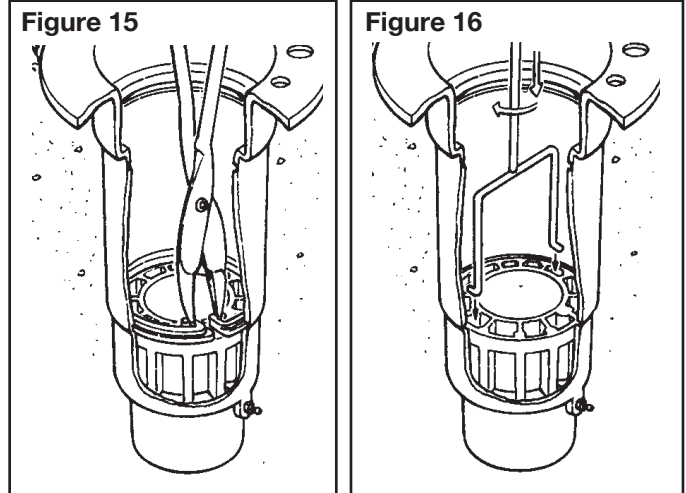

- Load snap ring onto insertion tool carrier with stepped side against carrier as shown in **Figure 17**. While holding snap ring in compressed position, slide retainer clip in to hold snap ring ears
- Load valve assembly on carrier as shown.
- Locate position of communication tube in bottom of sprinkler body and orient insertion tool accordingly.
- Insert tool straight down into sprinkler body aligning bosses on t-handle with holes on sprinkler body flange. When valve assembly clears vertical side wall ribs inside body, pull up on snap ring release mechanism (FLX55 models only) and press valve assembly into position. Snap ring will lock into groove when properly installed. Remove insertion tool and check snap ring to confirm that it is fully seated in groove.

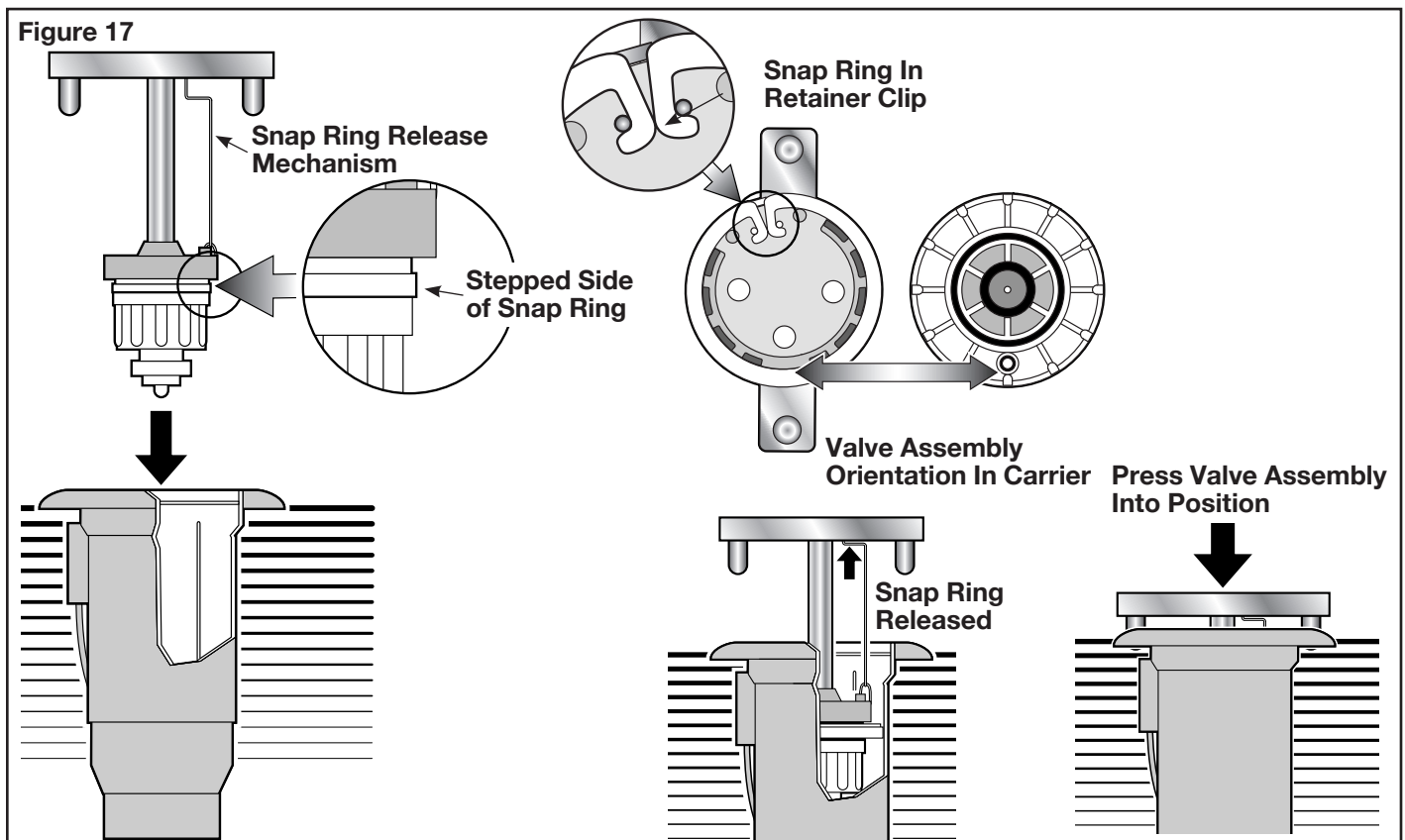

Servicing Pilot Valve

WARNING! Never stand or lean over the sprinkler while the irrigation system is being filled, during manual or automatic operation or when performing sprinkler service procedures. Direct contact with irrigation spray, a failed or improperly installed sprinkler connection or sprinkler components forcibly ejected upward under pressure can cause serious injury.

Note: Refer to **Figure 18** for the following procedure.

- Step 1** – Make sure that the water supply to sprinkler is positively shut off and any residual pressure has been bled off. If the sprinkler is pressurized, main valve will open when the pilot valve is disconnected from control tube.
- Step 2** – Carefully remove turf and soil from the side of the sprinkler to expose pilot valve and control tubing.
- Step 3** – Remove the two retaining screws from the pilot valve housing.
- Step 4** – Pull the pilot valve assembly away from the sprinkler body and cut the control tubing just below tube retainer. Unless pilot valve has been previously removed, control tubing length will be sufficient for re-connection.
- Step 5** – Remove tube retainer and remaining piece of control tubing from valve body fitting.
- Step 6** – Remove the solenoid (1, 2 or 3) or Normally-Closed hydraulic actuator (4) by turning it counterclockwise.
- Step 7** – Remove the retaining nut (18) and washer (17) from the pressure adjuster (11) and pull the pilot valve body assembly out of housing (16).
- Step 8** – Remove diaphragm assembly (15), piston (14), spring (13), traveling adjuster (12), pressure adjuster (11) and o-ring (7).
- Step 9** – Remove selector shaft assembly (9) and plunger assembly (5). (The selector shaft retains the plunger in the valve body.)
- Step 10** – Thoroughly clean and inspect all parts. Replace damaged parts as necessary and reassemble in reverse order.
- Note:** For service part numbers, refer to www.toro.com and click Parts. Select the “Irrigation” category and search for “Pilot Valves”.

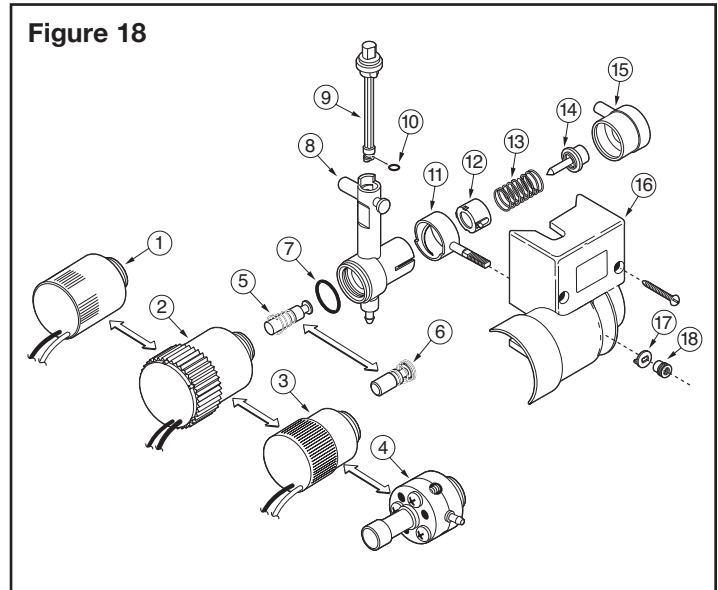

Flushing Sprinklers

WARNING! Never stand or lean over the sprinkler while the irrigation system is being filled, during manual or automatic operation or when performing sprinkler service procedures. Direct contact with irrigation spray, a failed or improperly installed sprinkler connection or sprinkler components forcibly ejected upward under pressure can cause serious injury.

- Step 1** – With sprinkler operating, carefully step down on center of cap several times. Water will flow around riser and flush out debris.
- Step 2** – Cycle sprinkler on and off several times to check for proper retraction. Cap should be even with top of body flange when fully retracted. If riser sticks in up position, check for debris lodged between riser and body. Flush out all debris. Remove sprinkler mechanism if necessary.

